

XS 20

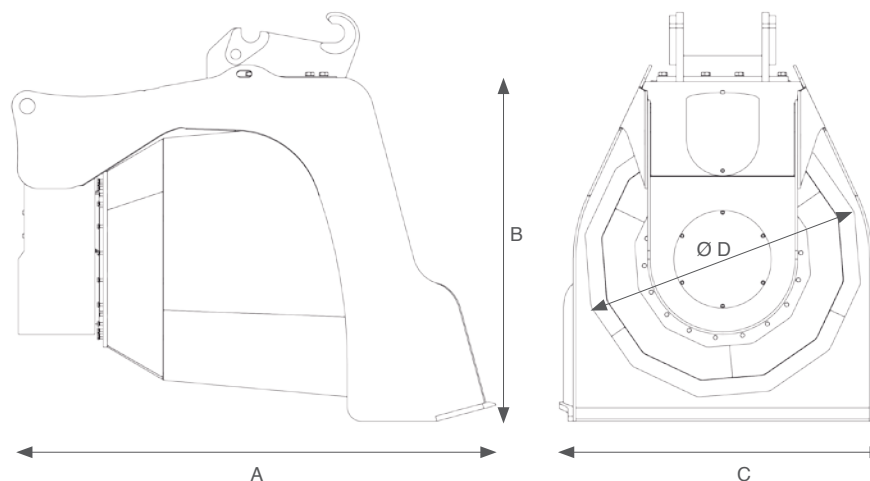

ESPECIFICACIONES TÉCNICAS XS20

Tamaño de la excavadora	Ton.	18 a 25
Peso (sin cabezal de anclaje)	kg	1.550
Presión de trabajo	MPa	20
Caudal de trabajo	L/min	160 - 180
Ø tromel	mm	1.300
Largo tromel	mm	1.230



	A	B	C	Ø D
XS20	2.500	1.700	1.610	1.300

XCENTRIC RIPPER INTERNATIONAL, S.L.

Arriurdina, 15 • 01015 Vitoria-Gasteiz (Spain) • Tel.: +34 945 290 555

www.xcentricripper.com