

XR 120

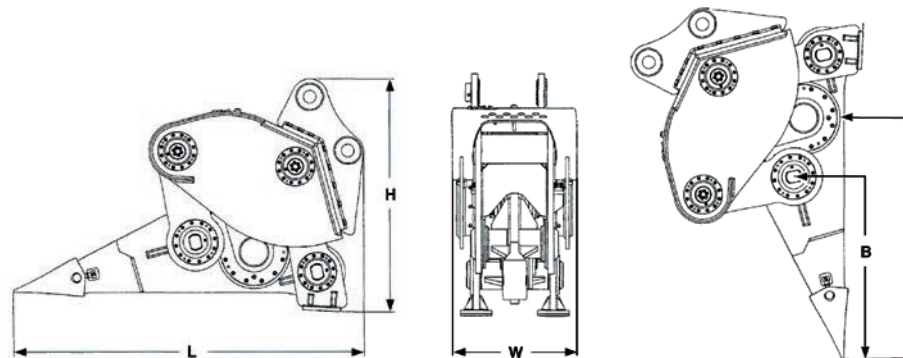

Item		XR 120 - 3M	XR 120 - 4M
Hydraulic excavator	tons	100 - 150	100 - 150
Mass of ripper (incl. top bracket)	kg	13000	13000
Mass of ripper (less top bracket)	kg	11000	11000
Hydraulic working pressure	MPa	30 - 32	22 - 24
Hydraulic return pressure	MPa	0.6	0.6
Hydraulic oil flow	L/min	500	600
Case drain maximum pressure	MPa	0.4	0.4
Frequency	1/min	1000	1000
Dimensions L x W x H	cm	400 x 132 x 282	400 x 132 x 282
Dimension A	cm	243	243
Dimension B	cm	180	180
Accumulator pressure	MPa	0.6	0.6



XCENTRIC RIPPER INTERNATIONAL, S.L.

Arriurdina, 15 · 01015 Vitoria-Gasteiz (Spain) · Tel.: +34 945 290 555

www.xcentricripper.com