

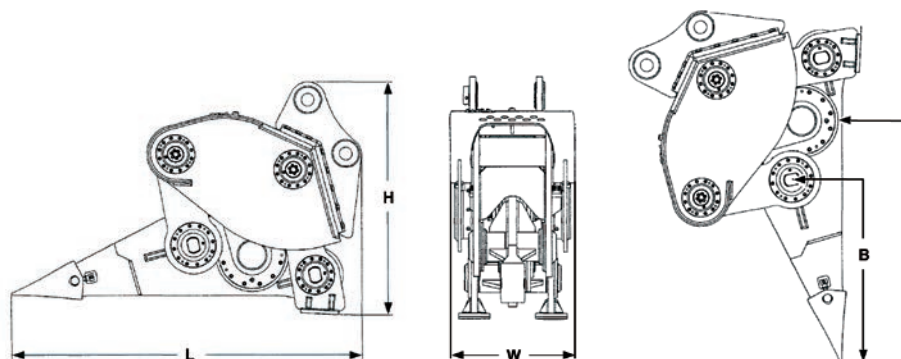

XR 20



Item		XR 20
Hydraulic excavator	tons	18 - 24
Mass of ripper (incl. top bracket)	kg	2500
Mass of ripper (less top bracket)	kg	2200
Hydraulic working pressure	MPa	18 - 20
Hydraulic return pressure	MPa	0.6
Hydraulic oil flow	L/min	160
Case drain maximum pressure	MPa	0.4
Frequency	1/min	1400
Dimensions L x W x H	cm	240 x 78 x 175
Dimension A	cm	165
Dimension B	cm	130
Accumulator pressure	MPa	0.5



XCENTRIC RIPPER INTERNATIONAL, S.L.

Arriurdina, 15 · 01015 Vitoria-Gasteiz (Spain) · Tel.: +34 945 290 555

www.xcentricripper.com