

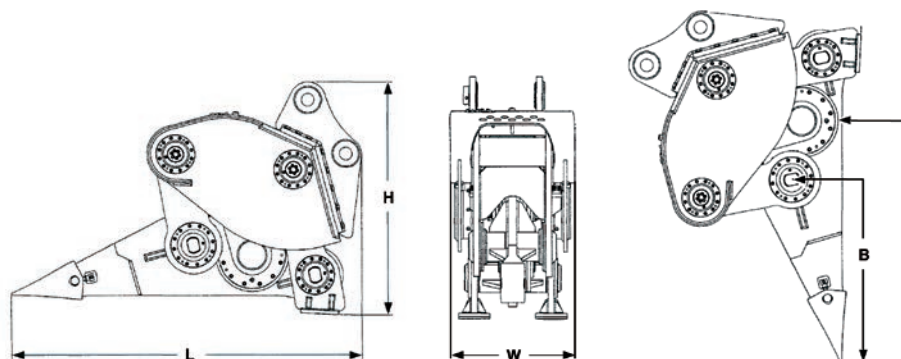

XR 15



Item	XR 15	
Pelle hydraulique	tonnes	11 - 16
Poids du ripper avec platine	kg	1700
Poids du ripper sans platine	kg	1550
Pression hydraulique	MPa	16 - 19
Pression retour	MPa	0.6
Débit hydraulique	L/min	120
Pression max dans le drain	MPa	0.4
Fréquence	1/min	1400
Dimensions L x W x H	cm	220 x 66 x 130
Dimension A	cm	140
Dimension B	cm	105
Pression accumulateur pneumatique	MPa	0.5



XCENTRIC RIPPER INTERNATIONAL, S.L.

Arriurdina, 15 · 01015 Vitoria-Gasteiz (Spain) · Tel.: +34 945 290 555

www.xcentricripper.com