

We are Xcentric. Better. Faster. Stronger.



*Screening bucket with  
**Powerboost system***

[www.xcentricripper.com](http://www.xcentricripper.com)

# High performance screening bucket

**XCENTRIC SCREENER**, is a high-performance screening bucket, rotating trommel type.

In its manufacturing, several variants have been combined, that improves the traditional screening technology:

## ✓ Polygonal trommel

- The 12-sided polygonal trommel, shakes the material inside more efficiently.
- Its longer length compared to other screeners, offers a larger screening area, thus reducing the working time in each cycle. This greater length of trommel is possible thanks to the large diameter of the main roller bearing.
- The hexagonal profile of the screening mesh, is the best choice between maximum yield and more homogeneous screening. The standard mesh sizes available are hexagonal with openings of 20, 30, 40, 50, 60 and 80 mm.

## ✓ Transmission by Time Belt

- The transmission between the main hydraulic motor and the trommel, is done by a time belt. This belt is able to transmit a great torque, besides being free of maintenance and/or periodic tensioning.

## ✓ Powerboost

- The Powerboost system applies vibration to the trommel while turning, greatly increasing production. It is a high frequency, low amplitude vibration, that does not affect the mechanical part of the Xcentric Screener, or the excavator.
- The Xcentric Screener can be supplied without the Powerboost option, being ready for later installation.

# Technical Specifications

TECHNICAL SPECIFICATIONS		XS20	XS40	XS50	XS60
Excavator size	Tons	18 - 25	24 - 38	37 - 55	55 - 70
Weight (without top plate)	kg	1.550	2.200	4.730	6.000
Operating pressure	MPa	20	25	25	20
Operating Flow	L/min	160 - 180	180 - 200	100	130
Ø trommel	mm	1.300	1.600	1.870	1.940
Trommel length	mm	1.230	1.425	1.780	1.945

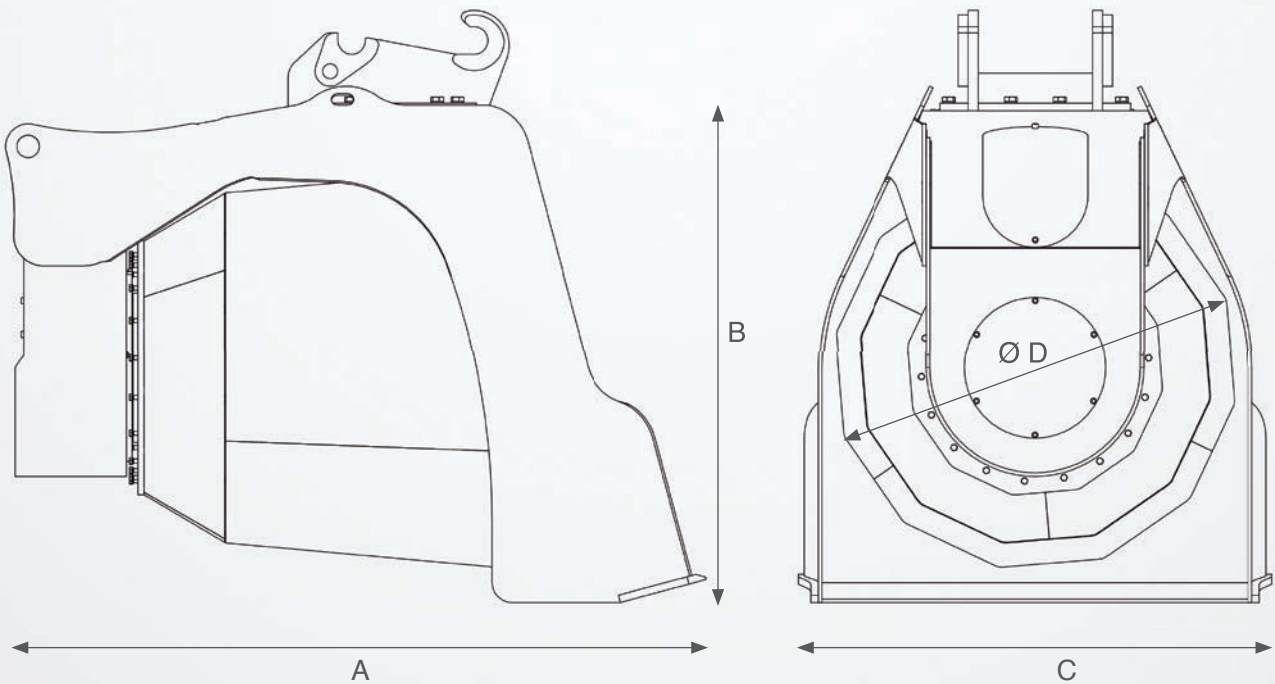

	A	B	C	Ø D
<b>XS20</b>	2.500	1.700	1.610	1.300
<b>XS40</b>	2.800	2.000	1.890	1.600
<b>XS50</b>	3.280	2.510	2.380	1.870
<b>XS60</b>	3.620	2.740	2.690	1.940



## Xcentric Screener benefits

- ✓ **Polygonal trommel:** shakes the material more efficiently
- ✓ **Hexagonal screening mesh profile**
- ✓ **Trommel with longer length:** larger screening area
- ✓ **Transmission by toothed Time Belt**
- ✓ **Main roller bearing of large diameter**
- ✓ **Powerboost system:** applies high frequency and low amplitude vibration to the trommel (optional)



**XCENTRIC RIPPER INTERNATIONAL, S.L.**

Arriurdina, 15. · 01015 Vitoria-Gasteiz (España) · Tel.: +34 945 290 555

[www.xcentricripper.com](http://www.xcentricripper.com)