

XCENTRIC

excavator **ATTACHMENTS**

RIPPER · CRUSHER · SCREENER · BUCKETS · COUPLERS



WE MANUFACTURE
**HIGH PERFORMANCE
ATTACHMENTS.**
WE WORK TO OFFER YOU
SOLUTIONS.



CONTENT

- Our company
- XCENTRIC RIPPER - hydraulic ripper
- XCENTRIC CRUSHER - crushing bucket.....
- XCENTRIC CRUSHER XC5F -
for skid steers, telescopic and mixed loaders.....
- XCENTRIC SCREENER - screening bucket.....
- XCENTRIC BAABOR - lobe shaft screener bucket
- 'GO' buckets and couplers.....
- After-sales service and training.....



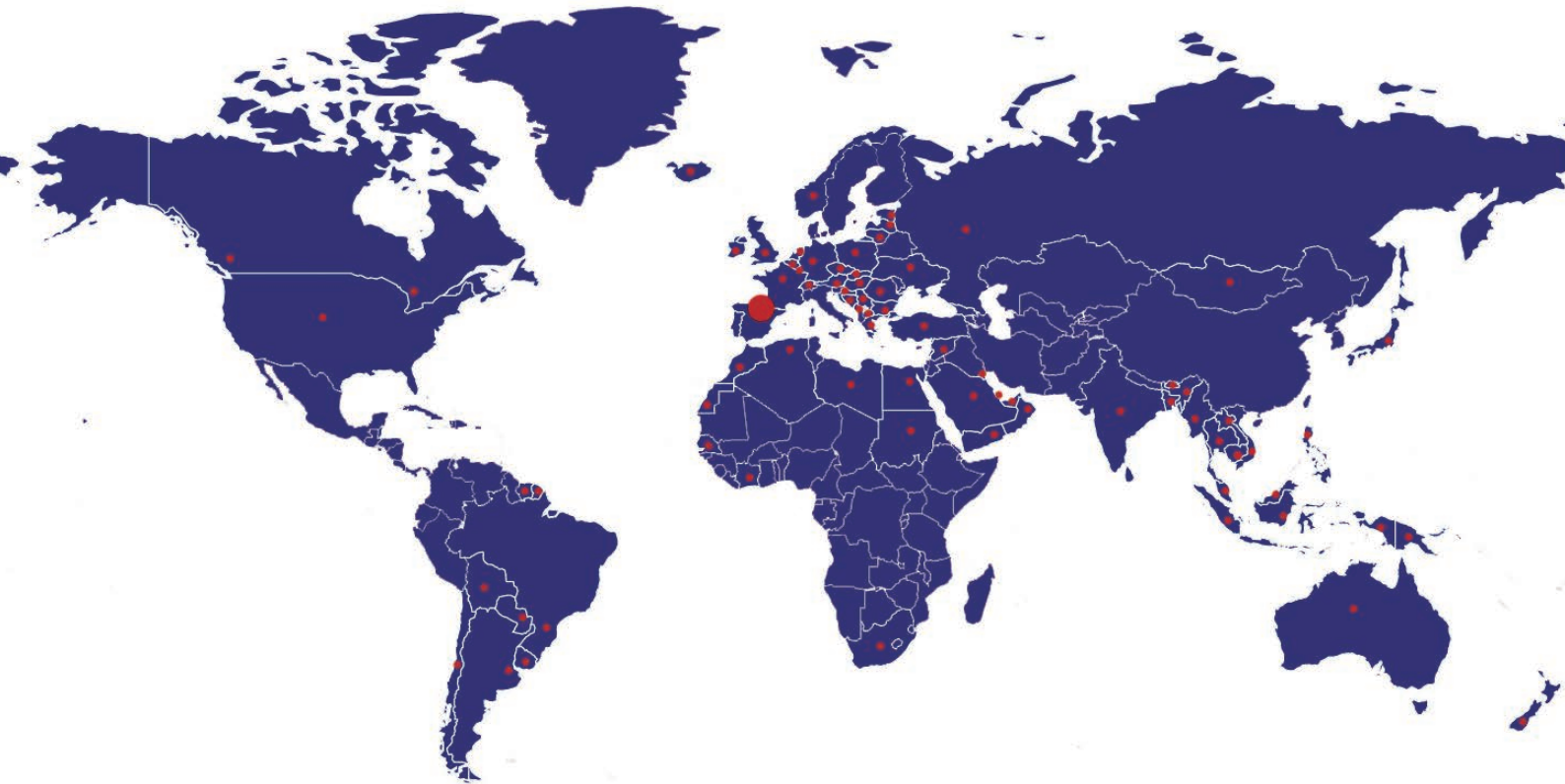

Countries in
which we are
present



Official
Xcentric
dealers



Xcentric
factory,
in Spain

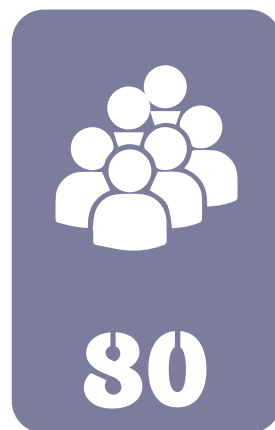

Employees
in the factory
in Spain

**HEADQUARTERS/FACTORY:
XCENTRIC RIPPER INTERNATIONAL, S.L.**

Arriurdina, 15. Pol. Ind. Júndiz. 01015 Vitoria-Gasteiz. Spain
Tel.: +34 945 290 555 · info@xrint.es

XCENTRIC[®]
www.xcentricripper.com

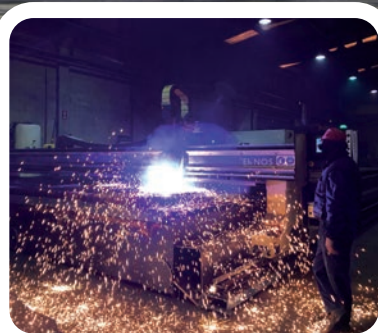
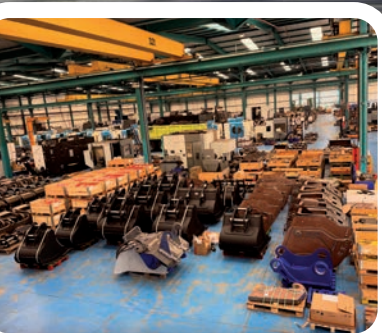

OUR COMPANY

Xcentric Ripper International, S.L., a Spanish company located in Vitoria-Gasteiz, was established in **2010** for the national and international marketing of excavator attachments.

At **Grado Cero Sistemas, S.L.U.**, a group company, we develop and manufacture all our products. This company was born in **1990**, acquiring an important presence in the national market over the years. In 1991 it developed its first quick coupler of its own design for excavators.

For our manufacturing process we have two production plants in Vitoria-Gasteiz: cutting-welding and manufacturing-assembly. Both provided with a **high-tech and latest generation machinery** structure, with which we are capable of responding to the highest quality requirements, as well as achieving agile delivery times.

We offer innovative and reliable attachments such as the **Xcentric Ripper** hydraulic ripper, **Xcentric Crusher** bucket, **Xcentric Screener** bucket and the lobe shaft screener bucket **Xcentric baabor**, as well as **GO MAX quick couplers** and a wide range of **buckets**.

We work with an extensive network of **official dealers** worldwide, with **technical advice** and **after-sales service** centers in more than 70 countries, which allows us to have a presence in around 100 countries.

COMPANY



XCENTRIC RIPPER

Series 0



The **Xcentric Ripper** is a hydraulic attachment for excavators, developed with a **Patented** “*Energy Accumulation Impact Technology*” **System**, which makes it, in 80% of work applications, more productive than any hydraulic hammer available on the market.

Made entirely from wear-resistant steel, it requires virtually no maintenance and is quieter than any other digging tool. It can be used underwater without risk of damage and is adaptable to countless workplaces. Some of its main applications are: excavation in quarries, construction, trenches, permafrost, tunnels, demolitions, recycling (slag), mining and underwater work.

This first series is intended for **excavators from 8 to 150 tons**, and the available models are the following: **XR10, XR15, XR20, XR30, XR40, XR50, XR60, XR80** and **XR120**.

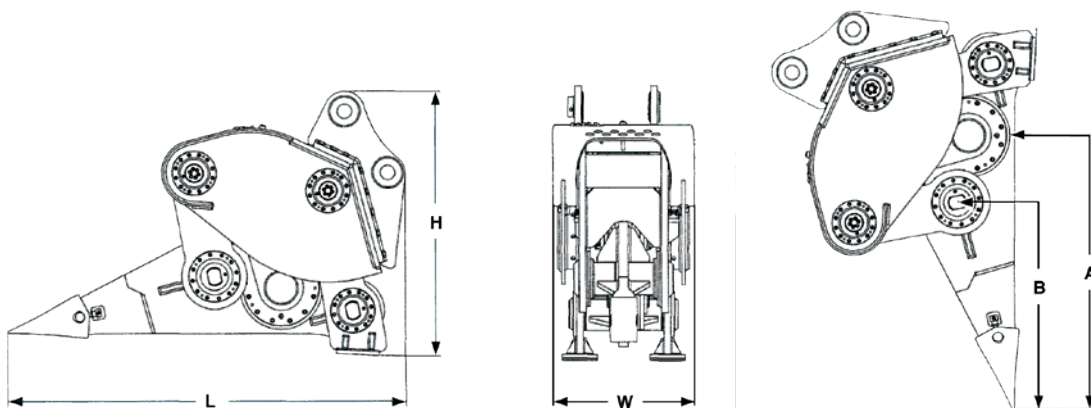

RIPPER



- Production 3 to 5 times higher than hydraulic hammer
- Minimum noise levels
- Minimum maintenance, no daily lubrication required
- Minimum wear parts consumption
- Less fuel consumption m³/ton produced
- Less emissions per m³/ton produced
- Environmental protection (Bio lubricants)
- Economic alternative to “Drilling and blasting”
- Marine/under water operation without any modification
- Easy operation and improves operator comfort
- Saving time and fuel

TECHNICAL SPECIFICATIONS		XR10	XR15	XR20	XR30	XR40
Excavator weight	Tons	7 - 10	11 - 16	18 - 24	24 - 30	32 - 40
Ripper operating weight (incl. top bracket)	kg	930	1.700	2.500	3.300	4.200
Ripper operating weight (top bracket not incl.)	kg	829	1.550	2.200	2.800	3.600
Hydraulic working pressure	MPa	15 - 18	16 - 19	18 - 20	22 - 24	22 - 24
Hydraulic return pressure	MPa	0,6	0,6	0,6	0,6	0,6
Hydraulic oil flow	L/min	60	120	160	180	200
Case drain maximum pressure	MPa	0,4	0,4	0,4	0,4	0,4
Frequency	1/min	1.500	1.400	1.400	1.300	1.200
Dimensions L x W x H	cm	168x45x90	220x66x130	240x78x175	280x85x175	310x90x184
Dimension A	cm	102	140	165	179,1	200
Dimension B	cm	76	105	130	139,1	155
Accumulator pressure	MPa	0,6	0,5	0,5	0,5	0,5

TECHNICAL SPECIFICATIONS		XR50	XR60	XR80	XR120
Excavator weight	Tons	42 - 55	55 - 70	70 - 100	100 - 150
Ripper operating weight (incl. top bracket)	kg	5.600	7.000	10.500	13.000
Ripper operating weight (top bracket not incl.)	kg	5.000	5.700	8.700	11.000
Hydraulic working pressure	MPa	26 - 28	26 - 28	30 - 32	30 - 32
Hydraulic return pressure	MPa	0,6	0,6	0,6	0,6
Hydraulic oil flow	L/min	250	280	380	500
Case drain maximum pressure	MPa	0,4	0,4	0,4	0,4
Frequency	1/min	1.000	1.000	1.000	1.000
Dimensions L x W x H	cm	320x90x190	345x110x217	380x132x230	400x132x282
Dimension A	cm	210	226	240	243
Dimension B	cm	165	176	180	180
Accumulator pressure	MPa	0,4	0,25	0,6	0,6



XCENTRIC RIPPER

Series 2 - 'Mining Series'



This second series, called '**Mining Series**', was designed with jobs such as mining in mind, where the highest production values are necessary, as well as continuous work shifts, where reliability and working comfort with the excavator are vitally important.

The working technology is basically the same as in the standard version, but not the **mechanics**, which have been **reinforced** to achieve a **greater impact at a lower frequency**. A drive pinion has been added to the set of eccentrics, to which the motor is now connected, developing this way a slower movement.

In addition, several **changes** have been made to the **shell design**, such as adding a window to monitor accumulator pressure, and reinforcements in the lower pivot arm and in the ripper arm.

With all these changes it is possible to reduce the possibility of mechanical problems and gain strength to break harder rock.

This series is intended for **excavators from 18 to 140 tons**, and the available models are the following: **XR22, XR32, XR42, XR52, XR62, XR82** and **XR122**.

RIPPER



- Same advantages and applications as the Series 0
- Narrower housing, to have greater visibility, better for working in trenching...
- Reinforced housing to prevent wear and cracks
- Window for easy inspection of the accumulator's correct pressure
- Lower pivot arm and ripper arm cast reinforced for longer wear life
- Accumulator protected by the housing to prevent the entry of stone
- Reinforced mechanics with a drive pinion added to the eccentric assembly, to achieve a greater impact at a lower frequency

TECHNICAL SPECIFICATIONS		XR22	XR32	XR42	XR52	XR62	XR82	XR122
Excavator weight	Tons	18 - 23	24 - 32	32 - 40	40 - 55	55 - 70	70 - 90	100 - 140
Ripper operating weight (incl. top bracket)	kg	2.935	3.710	4.640	5.305	7.600	10.730	15.950
Ripper operating weight (top bracket not included)	kg	2.560	3.300	4.120	4.590	6.330	9.300	14.000
Hydraulic working pressure	MPa	16	24	24	28	28	30	30
Hydraulic oil flow	L/min	160	190	210	270	280	420	500
Frequency	1/min	900	1.100	1.100	1.100	1.100	700	600

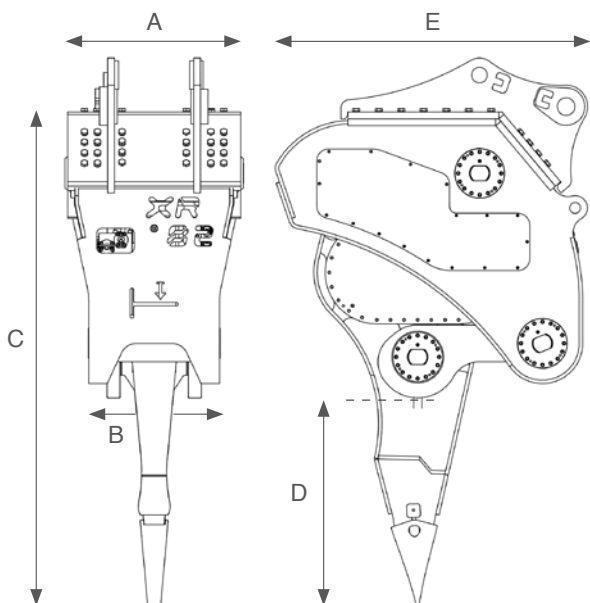

	XR22	XR32	XR42	XR52	XR62	XR82	XR122
A	830	775	860	960	1.100	1.270	1.270
B	780	635	630	630	1.100	960	1.080
C	2.243	2.715	2.865	3.000	3.450	3.575	4.150
D	1.000	1.160	1.215	1.315	1.380	1.530	1.780
E	1.600	1.660	1.715	1.830	2.170	2.300	2.600

* Dimensions in millimeters.



XCENTRIC CRUSHER

Series 'E'



The **Xcentric Crusher** is a high-quality, consistent-performance crushing bucket for rock crushing and material recycling. Built in HARDOX 400, solid, durable, characterized by its recognizable clean lines designed to resist wear and high stresses in the most difficult working conditions. Its versatility allows the use of this accessory in a variety of processes, such as reducing the use of heavy mechanical vehicles and the number of operators. Demolition materials can be reused directly on site, reducing transport costs and enabling environmentally friendly recycling.

It is manufactured with a **patented technology**, which applies a high inertia power train, a circular jaw movement, in addition to the new and simple anti-stalling plate. The granulometry adjustment system is simple and fast. Further, their crushing jaws can be placed crossed, which, together with their circular movement, makes these buckets capable of crushing wet material without compaction effect.

The **'E' series** is intended for **excavators between 13 and 35 tons**, and counts with the following models: **XC15, XC17, XC20** and **XC30**.

CRUSHER



- Minimum maintenance (50 h. greasing intervals)
- High inertia power train
- Isolating circular jaw movement
- Anti-stagnation plate
- Simple and fast granulometry adjustment
- Anti-stagnation plate
- Crossed jaws: together with the circular movement, they allow crushing wet material
- Double effect: it can be unclogged without emptying
- Inertia wheels placed inside and protected by the housing
- Cantilevered loading mouth: it avoids wear and fracture

TECHNICAL SPECIFICATIONS		XC15	XC17	XC20	XC30
Excavator size	Tons	13 - 15	16 - 20	20 - 25	24 - 35
Weight (without top plate)	kg	2.000	2.000	2.500	3.750
Operating pressure	MPa	32	25	25	25
Operating flow	L/min	110	155	175	190
Max. drain pressure	MPa	0,4	0,4	0,4	0,4
Hydraulic circuit		Double effect	Double effect	Double effect	Double effect
Loading capacity	m ³	0,5	0,5	0,8	1
External width	mm	930	930	900	1.070
Internal width	mm	730	730	730	900
Length	mm	2.050	2.050	2.465	2.575
Height	mm	1.200	1.200	1.300	1.400
Crushing size	mm	20 - 90	20 - 90	20 - 140	20 - 140
Jaw opening	mm	400	400	420	420

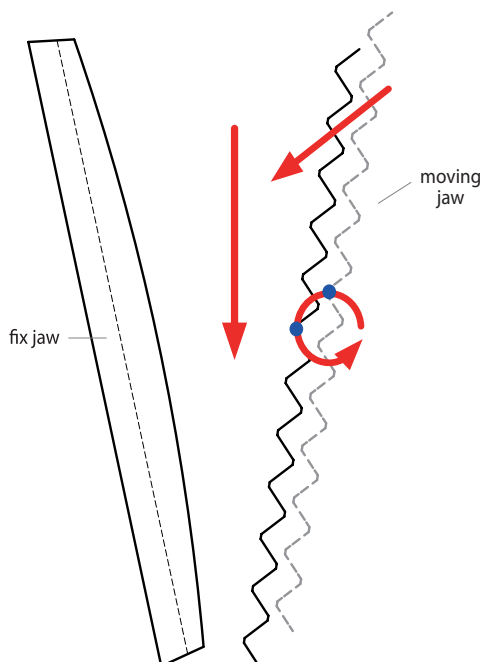

Crushing jaws

Placing the crushing jaws in a cross position, together with its circular motion, gives the Xcentric Crusher the faculty of grinding wet material.

This way, what you get is the movable jaw to “bite” the wet material and together with the circular movement drag it to the outlet, without sticking to the walls of the bucket.



XCENTRIC CRUSHER

Series 'A'



The Xcentric Crusher **'A' Series** came onto the market with a new and innovative design, its main features being the following:

- A new *granulometry adjustment system* that offers speed of change, along with a greater possibility of output sizes.
- The *flow control valve* makes the equipment easily interchangeable between excavators, with very low risk of breakdown in case of poor hydraulic adjustment.
- *Replacing the jaws* in case of wear is very simple, since the bucket can be completely wide opened to carry out this operation.

The "A" series has a thoroughly redesigned power train. The flywheel integrated inside the bucket makes it possible to fully load the Crusher, put it in working position and start.

In case of stagnation of any metal part inside, as is common in Crushers, the "Reverse" function will unclog the jaws without having to empty the load.

The **'A' series** is intended for **excavators between 8 and 38 tons**, and has the following models: **XC8, XC9, XC13, XC19, XC21, XC24** and **XC29**.

CRUSHER



- High profitability than mobile crushers
- Unquestionably profitable production
- volumes
- Redesigned power train, unstoppable
- Anti-stagnation plate
- Simple and fast granulometry adjustment
- system
- Timing belt transmission
- Manufactured entirely in HARDOX 400
- REVERSE unblocking function
- Clean design without fairings
- Very easy replacement of the jaws

TECHNICAL SPECIFICATIONS		XC8	XC9	XC13	XC19
Excavator size	Tons	8 - 11	10 - 13	13 - 16	16 - 21
Weight (top plate not included)	kg	1.400	1.835	2.165	2.560
Operating pressure	MPa	25	25	25	25
Maximum operation flow	L/min	80	95	120	160
Hydraulic circuit		Shear mode	Shear mode	Shear mode	Shear mode
Loading capacity	m ³	0,35	0,35	0,42	0,5
External width (A)	mm	850	930	930	1.100
Internal width (B)	mm	660	730	730	900
Length (C)	mm	1.670	1.700	1.940	1.940
Height (D)	mm	880	930	1.000	1.040
Crushing cam opening (H)	mm	h 260	h 370	h 370	h 370
Output size regulation	mm	0-16 to 0-200	0-16 to 0-200	0-16 to 0-200	0-16 to 0-200

TECHNICAL SPECIFICATIONS		XC21	XC24	XC29
Excavator size	Tons	20 - 25	24 - 33	28 - 38
Weight (top plate not included)	kg	3.500	4.000	5.540
Operating pressure	MPa	25	25	25
Maximum operation flow	L/min	160	180	200
Hydraulic circuit		Shear mode	Shear mode	Shear mode
Loading capacity	m ³	0,7	1	1,2
External width (A)	mm	930	1.075	1.280
Internal width (B)	mm	730	900	1.100
Length (C)	mm	2.480	2.480	2.620
Height (D)	mm	1.250	1.305	1.360
Crushing cam opening (H)	mm	h 370	h 370	h 440
Output size regulation	mm	0-16 to 0-250	0-16 to 0-250	0-16 to 0-250

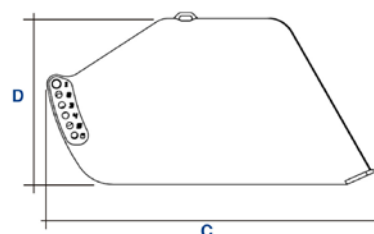
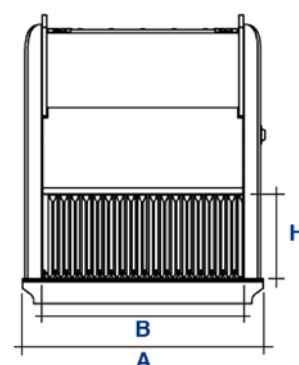



XCENTRIC CRUSHER

XC5F



The **Xcentric Crusher XC5F**, a front-end crusher, was developed to meet the demand of customers in the most advanced countries in recycling construction materials. The types of machinery they normally use are **mini loaders, telescopic and mixed loaders**.

With this crusher it has been possible to work with flow rates of 90 l/min. and pressures ranging between 16 MPa and 24 MPa. The material input capacity is w810mm x h360mm, ensuring that practically all the material to be ground in this type of work is admitted directly by the crusher, without having to previously reduce its size.

Thanks to the dynamic movement of our mobile jaw, this model allows you to **grind in 2 directions**: “forward”, for dry material and larger pieces, and “reverse”, for better results in wet material and especially in asphalt. The operator can change the mode immediately from the joystick if necessary.

A **new shock absorber system** achieves a very important acoustic reduction, as well as less vibration of the excavator. These shock absorbers are adjusted manually after changing from one granulometry to another, without any type of tool.

The **direct drive** of the hydraulic motor reduces mechanisms and is free of belts. It requires greasing every 8 hours of work in 6 points perfectly located in the upper part of the disposer.

CRUSHER

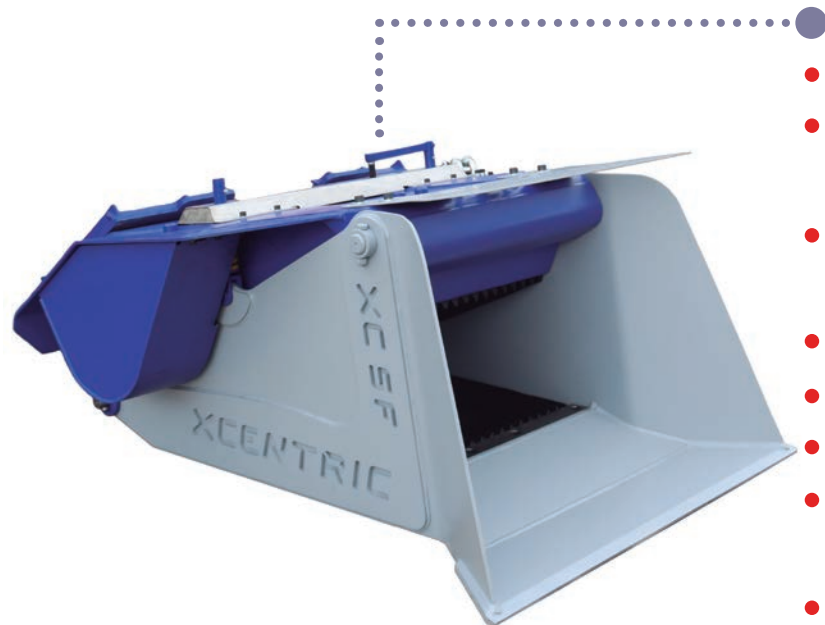

- Recycling materials on site
- New system of dampers: very important acoustic reduction
- Direct drive of the hydraulic motor (“direct drive”): reduces mechanisms
- Minimum and easy maintenance
- Input capacity for big material
- Fast and efficient change of granulometry
- It supports crushing in 2 directions: “forward” and “reverse”
- Very careful structural design
- Very fast and easy jaw replacement

TECHNICAL SPECIFICATIONS		XC5F
Skid steer	Tons	4 - 6
Weight (top plate not included)	kg	1.700
Operating pressure	MPa	24
Maximum operation flow	L/min	90
Hydraulic circuit		Shear mode
Loading capacity	m ³	0,4
External width (A)	mm	1.360
Internal width (B)	mm	810
Length (C)	mm	1.800
Height (D)	mm	780
Crushing cam opening (H)	mm	360
Output size regulation	mm	0 - 80 (6 steps)

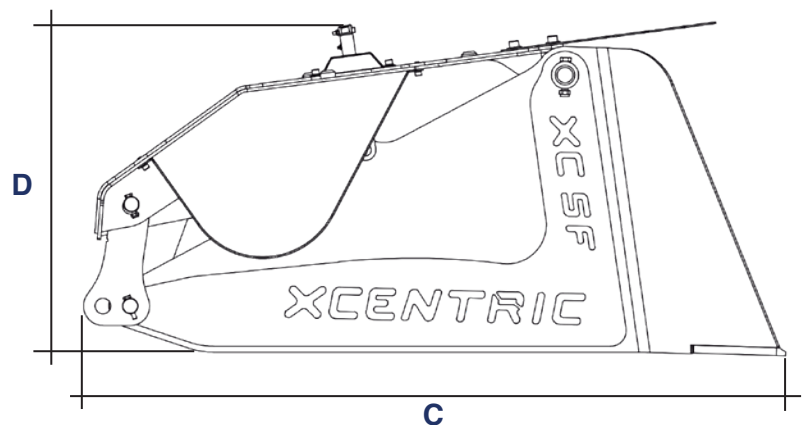
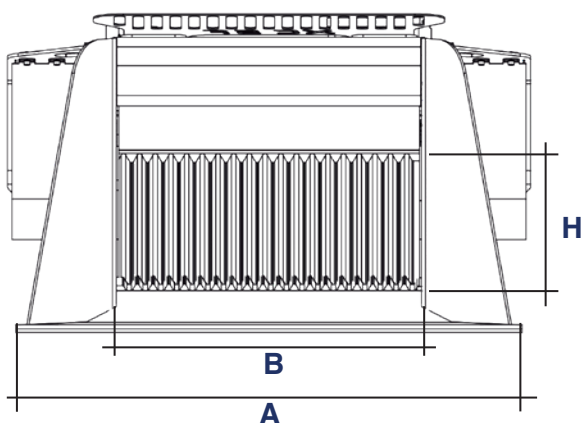



XCENTRIC SCREENER

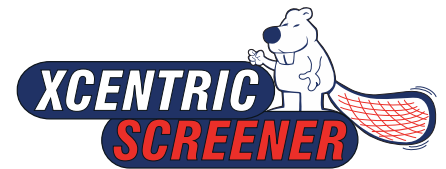

The **Xcentric Screener** is a high performance rotating trommel type screen bucket. Several variants have been combined in its manufacture that distinguish it from other screeners on the market:

- **Polygonal trommel:** 12-sided trommel that agitates the material inside more efficiently. Its greater length compared to other screeners offers a larger screening area, reducing work time in each cycle. This longer trommel length is possible thanks to the large diameter main roller bearing. The hexagonal profile of the screening mesh is the best option between maximum performance and more homogeneous screening. Standard mesh sizes available are hexagonal with openings of 20, 30, 40, 50, 60 and 80 mm.

- **Toothed belt transmission:** The transmission between the main hydraulic motor and the trommel is carried out by means of a toothed belt. This belt is capable of transmitting a large torque, in addition to being free of maintenance and/or periodic tensioning.

- **Powerboost System:** applies vibration to the trommel while it rotates, greatly increasing production. This is a high-frequency, low-amplitude vibration that does not affect the mechanical part of the Xcentric Screener or the excavator. The Xcentric Screener can be supplied without the Powerboost option, being prepared for later installation.

The **Xcentric Screener** is intended for **excavators between 18 and 70 tons**, and provides the following models: **XS20, XS40, XS50** and **XS60**.

SCREENER

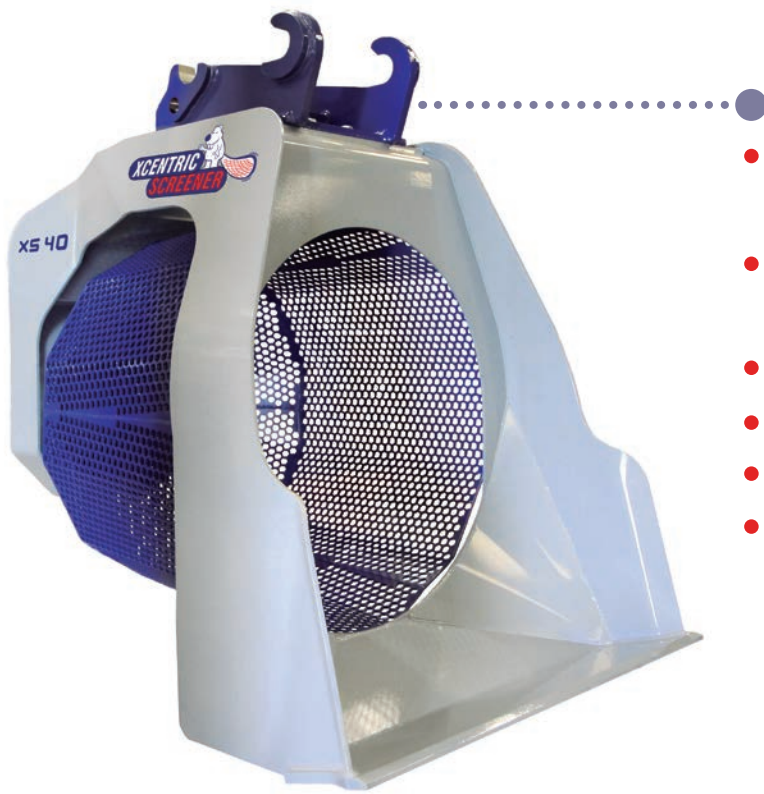

- Polygonal trommel: shakes the material more efficiently
- Trommel with longer length: larger screening area
- Main roller bearing of large diameter
- Hexagonal screening mesh profile
- Transmission by toothed Time Belt
- Powerboost system: applies high frequency and low amplitude vibration to the trommel (optional)

TECHNICAL SPECIFICATIONS		XS20	XS40	XS50	XS60
Excavator size	Tons	18 - 25	24 - 38	37 - 55	55 - 70
Weight (without top plate)	kg	1.550	2.200	4.730	6.000
Operating pressure	MPa	20	25	25	20
Operating flow	L/min	160 - 180	180 - 200	100	130
Ø trommel	mm	1.300	1.600	1.870	1.940
Trommel length	mm	1.230	1.425	1.780	1.945

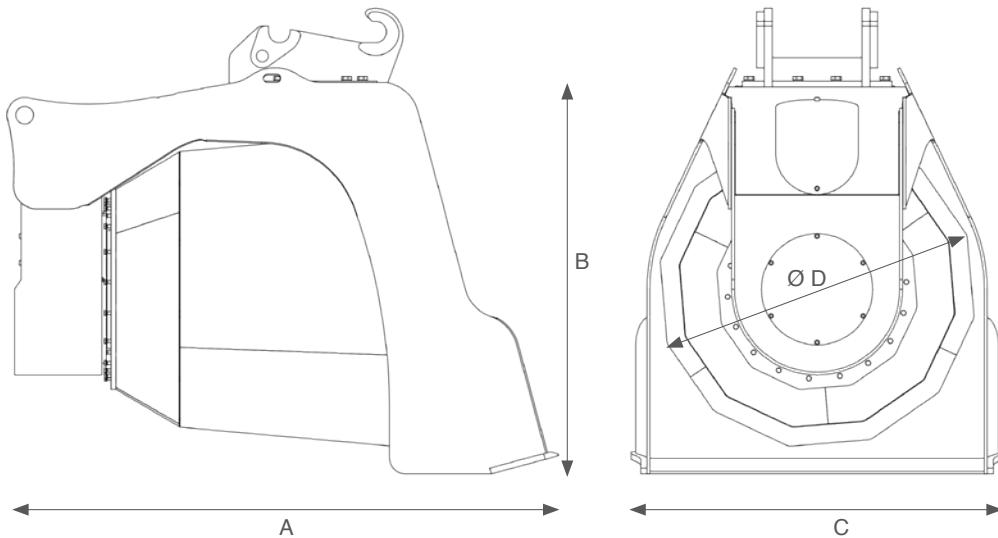

	A	B	C	Ø D
XS20	2.500	1.700	1.610	1.300
XS40	2.800	2.000	1.890	1.600
XS50	3.280	2.510	2.380	1.870
XS60	3.620	2.740	2.690	1.940



XCENTRIC BAABOR

XCENTRIC
baabor

The **Xcentric baabor** is an excavation bucket equipped **for screening work**. Hydraulically driven, the bucket sifts the material inside, removing fines smaller than the center distance and retaining larger solids inside. Its profile, similar to that of an excavation bucket, allows all the typical tasks of this type of bucket.

Our **innovative lobe profile system on the screening shafts** goes further than any other shaft screen on the market. With a silent, vibration-free movement, it gently agitates the material inside the bucket. This allows for screening materials sensitive to breakage, such as demolition waste containing bricks, wood, iron pieces, etc., as well as fine construction materials, without crushing any of these.

This feature makes our screen's mechanical requirements very low, which considerably reduces the equipment's weight, and its moving parts are completely maintenance-free.

We could call it "plug and play," as **it requires no hydraulic adjustments on the excavators**, nor technical assistance for installation and commissioning.

All of the above does not preclude the possibility of aggressive screening, such as rock at a quarry face.

BAABOR

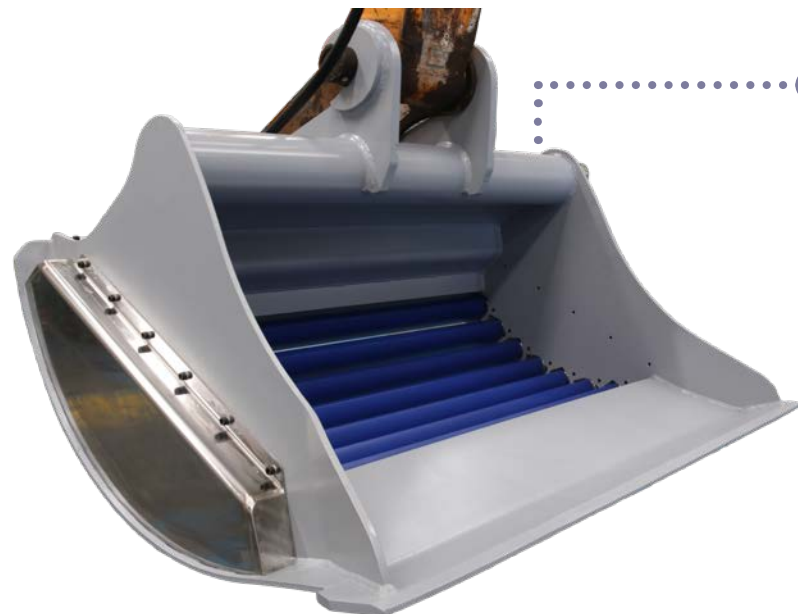

- Screening works
- Innovative lobe profile system on the screening shafts
- Silent movement
- Vibration-free
- It allows for screening materials sensitive to breakage
- Very low mechanical requirements
- Completely maintenance-free moving parts
- It requires no hydraulic adjustments on the excavators: “plug and play”
- The possibility of aggressive screening

TECHNICAL SPECIFICATIONS		B8.100.e	B16.130.e	B16.160.e
Excavator size	Tn.	8 - 13	14 - 18	18 - 23
Weight (top plate included)	kg	500	820	1.000
Operation pressure	MPa	14 to 18	14 to 18	14 to 18
Maximum operation flow	L/min	50	100	100
Hydraulic circuit		Shear mode	Shear mode	Shear mode
Loading capacity	m ³	0,4	0,9	1,2
External width (A)	mm	1.340	1.675	1.975
Internal width (B)	mm	1.000	1.300	1.600
Length (C)	mm	1.250	1.260	1.260
Height (D)	mm	800	1.220	1.220
Screening shafts options (e)	mm	8 to 50	8 to 50	8 to 50

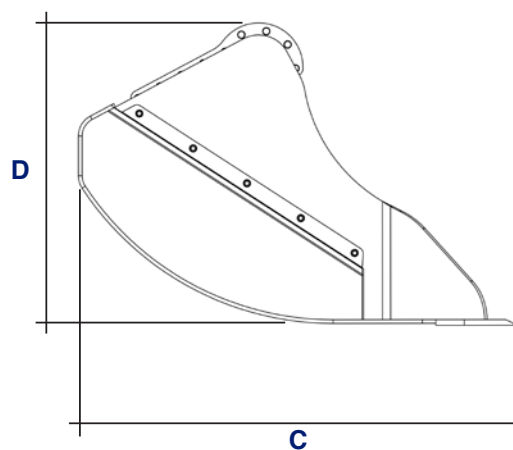
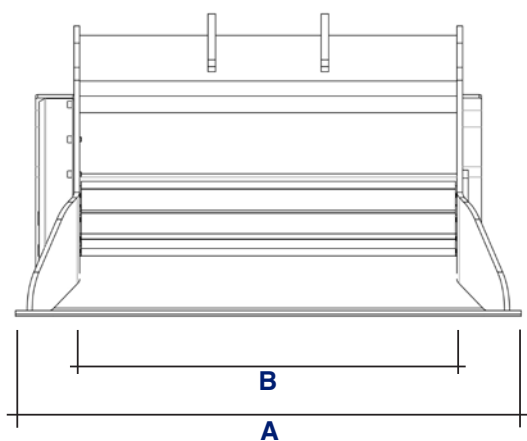



BUCKETS & COUPLERS **GO**

Since 1990, under the Grado Cero (GO) brand, we manufacture a wide range of **attachments** for excavators, **from 0.8 to 120 tons**.

The whole range of attachments is manufactured entirely from **HARDOX** wear-resistant steel. This steel offers, in addition to its abrasion resistance, yield strength and tensile strength values more than double those of commonly used steels. This results in a robust structure and a long service life for the bucket under good conditions.

The evolution in the designs of our attachments is basically focused on our experience, on the conclusions we reached after listening to users and on field tests. We look for the best combination to move the maximum load at the lowest cost.

As for **quick couplers**, our best-known hitch is the **GO MAX**, which was designed taking into account the following factors: minimum impact with respect to the original kinematics, **interchangeable with equipment from different brands and models of excavators**, with an improved design to adapt the size to various brands and provide the minimum additional weight for the machine, ease of installation and minimum maintenance. For mini excavators, in addition to the GO MAX, we have the **GO BIT** quick coupler.

Information about these buckets, hitches and other attachments is expanded on the Grado Cero website: **www.gradocero.net**

BUCKETS &



- Manufactured entirely in HARDOX 400
- Strong structure
- High durability
- Wide range from 0.8 to 120 tons
- Designed according to user needs

MODEL DK

MODEL M

MODEL L

MODEL G

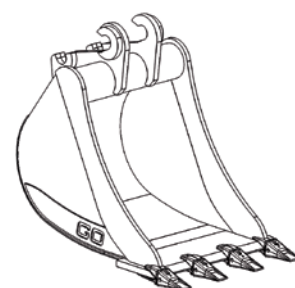
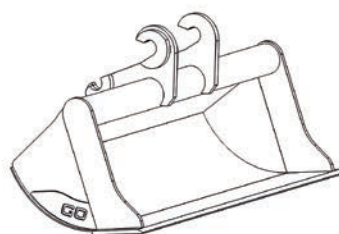
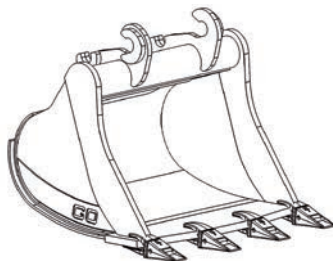
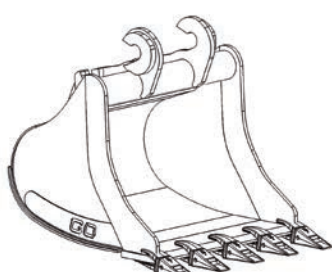

coupler GO MAX

- Interchangeable with equipment of different brands and models
- Minimum additional weight to the machine
- Ease of installation and minimal maintenance

GO MAX	Machine weight range	Maximum pin diameter	Maximum beam width
ST 50	7-11 Tn.(backhoe)	60 mm.	200 mm.
ST 65	10-15 Tn.	65 mm.	280 mm.
ST 80	15-25 Tn.	80 mm.	350 mm.
ST 90	24-30 Tn.	90 mm.	410 mm.
ST 100	28-36 Tn.	100 mm.	440 mm.
ST GENERIC	> 36 Tn.	-	-

COUPLERS



AFTER SALES SERVICE & TRAINING

- ● **SPARE PARTS:** Fast delivery of spare parts can be crucial for completing work on time. We prepare spare parts packages tailored to your needs.
- ● **TECHNICAL SUPPORT:** For faster troubleshooting, we provide easy-to-use and detailed user manuals.
- ● **TRAINING:** Our distributors also participate in ongoing training programs to provide the best possible service worldwide. To learn how to get the most out of our machines, contact your nearest distributor or us for more information.
- ● **MAINTENANCE:** If any machine needs a check-up or repair of any part, it is checked and re-tuned in our workshop.

AFTER SALES





WE ARE XCENTRIC. BETTER. FASTER. STRONGER.

| VISIT OUR WEBSITE TO SEE OUR NETWORK OF DEALERS |



XCENTRIC

www.xcentricripper.com

Arriurdina, 15. Pol. Ind. Júndiz · 01015 Vitoria-Gasteiz (Spain)
Tel.: +34 945 290 555 · info@xrint.es